



## Miniature Vibrating Fork Type Level Switch 135 VLM

The ever-growing popularity of the 135-VLM Miniature Vibrating Fork Type level Switches is ensured by their versatility, provided by their principle of operation. Vibrating Fork Level Switch 135-VLM is mainly for Liquids and free flowing solids. It works on the principle of a change in frequency of a Vibrating Fork due to presence of a liquid / solid.

### APPLICATION:

- The 135-VLM covers a large variety of level detection applications and more. high/low fail safe limit switch, overflow or dry run protection, pump controls, dry/wet indication in pipes etc.
  - All liquids for process vessels, tanks
  - To check presence of liquid in inlet, outlets pipings.
  - light, free flowing solids.
- PNP, open collector contact output (for use with PLC's and for Alarm Annunciation).
- Fit and forget device: simple installation, no maintenance
- Switching performance does not depend on the change of liquid conductivity, dielectric constant, viscosity, pressure and temperature.
- Suitable for Food, Edible oils and hydrogenated fats.
- Hygienic versions with various process connections for Milk / Food applications (For details about fine polishing contact factory).

### SPECIFICATION:

› Fork material	: SS316L
› Process connection	: Threaded 1"
› Maximum Pressure	: 40Bar Max.
› Media Temperature	: 0 to 60°C (Std.) : 0 to 80°C (HTSO)*
› Ambient Temperature	: 0 to 55°C
› Insertion Length	: 78-3000mm (See ordering code)
› Process connection size	: Min. 1" BSP
› Density of medium	: Liquid $\geq 0.7 \text{ kg/dm}^3$ : Solid $\geq 0.05 \text{ kg/dm}^3$
› Liquid Viscosity	: $< 10000 \text{ mm}^2/\text{s}$ (cst)
› Switching time	: 2 sec free
› Output mode indicator	: Bi-colour LED, Green - Normal Red flash - Alarm
› Sensitivity Settings	: For Liquids - Low - If density $\geq 0.7 \text{ kg/dm}^3$ : For Solids - Low - If density $\geq 0.05 \text{ kg/dm}^3$
› Housing material	: SS316
› Sensitivity Programming & Fail safe high/low	: LED sequence, Field selectable by magnetic key.
› Output rating	: DC PNP Transistor, 300mA(max)
› Electrical connections	: PG 11
› Supply Voltage	: 24VDC $\pm 10\%$
› Degree of Protection	: IP 65
› Power consumption	: $< 0.25\text{W}$

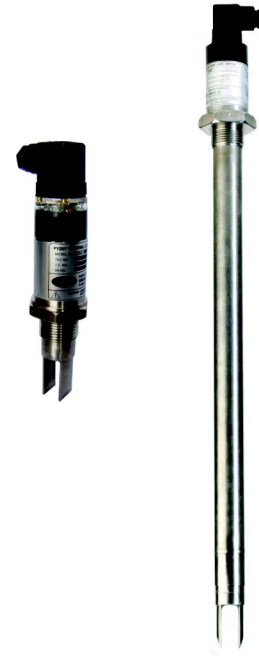

### FEATURES:

- › Low power microprocessor based intelligent device.
- › Compact in size.
- › Setting of FSH/FSL is possible without removal of instrument from process with the help of magnetic key. No down time required.
- › Protection against short circuited load.
- › Switch configuration programmable.
- › Health check feature.

**ORDERING CODE:**

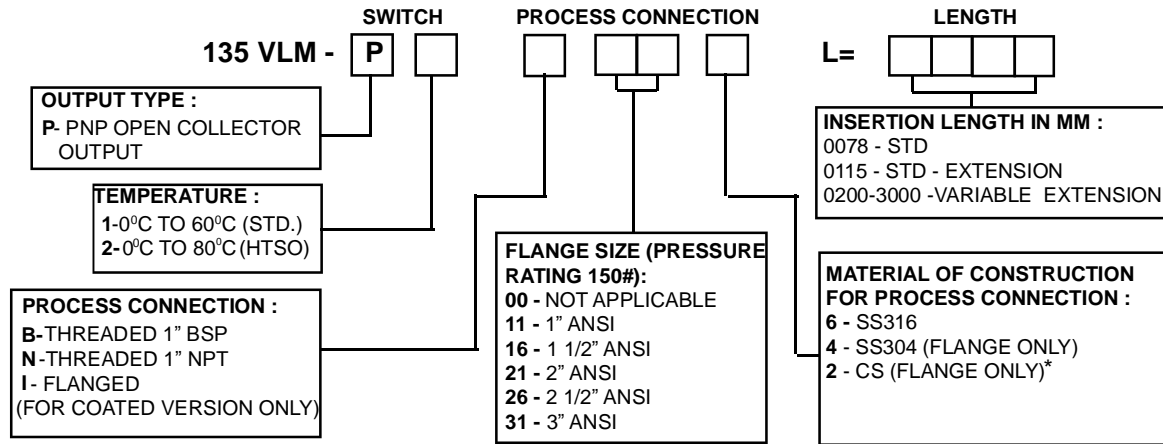

\* **Note:** Slip on Flange with suitable threading in required material e.g. CS/SS316/SS304, will be provided for all Flanged versions except coated.

**DIMENSIONAL DRAWING** **APPLICATION DRAWINGS**

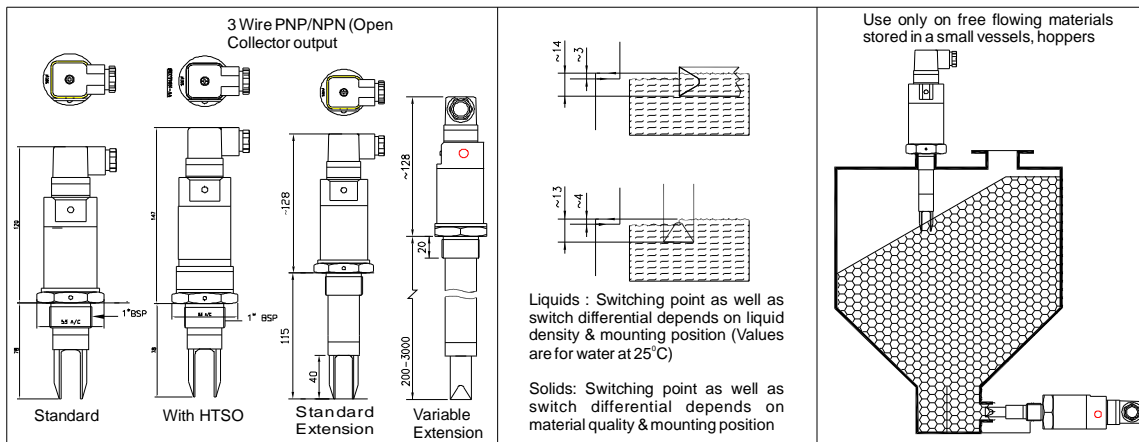

**PROCESS CONNECTION** **POSITIONING POINT** **ELECTRICAL CONNECTION**

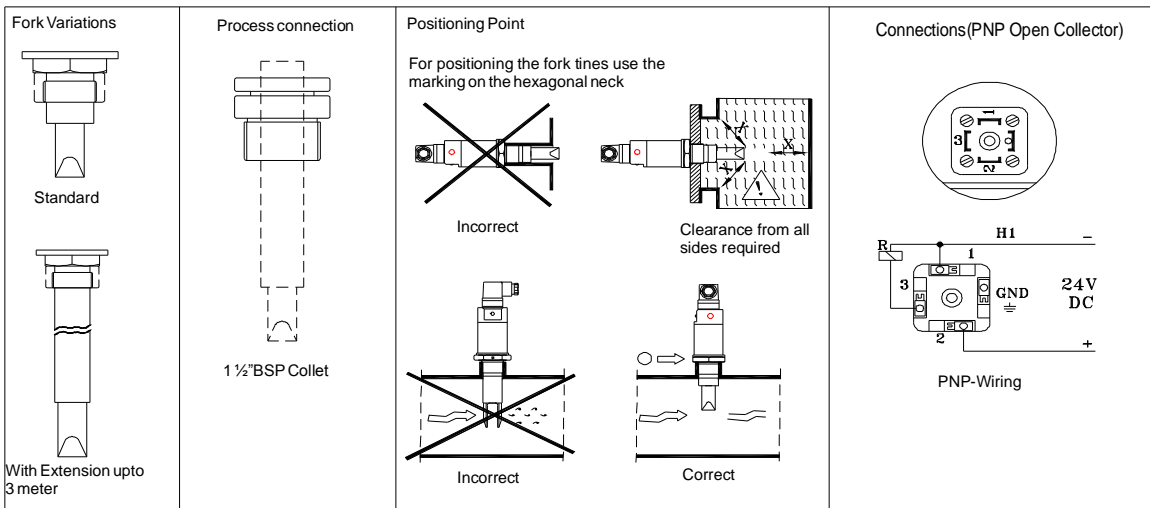

\*\*\* Continuous developments may necessitate changes without notice.

LF-135-0805 Rev.02 09/2012

LF\_MiniVibFork\_135VLM

SBEM Pvt. Ltd.

H.O. : 39, Electronic Co-Operative Estate, Pune - 411 009 (India)



ISO 9001: 2008

