

The LFB300 universal limit switch for liquids – rugged and reliable measurement of liquids using the tuning fork principle



to the universal measurement principle of the LFB300 and its flexible design. A tube-extended variant for vertical mounting with up to 6 metres switching distance to the top of the container is also available – the LFB330. A wide selection of flange, threads and hygienic connections allow customer-specific solutions. The device is suitable for hygienic applications and can be cleaned using SIP and CIP processes. There are also variants for use in potentially explosive atmospheres, to prevent overfilling (in compliance with WHG), and with marine certification.

Advantages:

- Rugged device design
- Flexible concept allows customer-specific solutions, particularly in hygienic areas and Ex-zones
- Teaching without filling
- Very high reproducibility

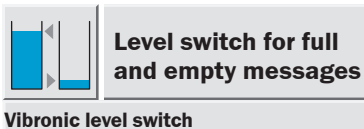

The level sensors of the LFB300 series are universally usable limit switches that detect predefined filling heights in liquid systems with millimetre-accuracy – even under difficult operating conditions. The measurement principle of the oscillating fork reacts to changes in density between the surrounding air and the liquid, and thus operates independently of the tank material, container structures or the liquid involved. The rugged sensor requires no calibration with the medium and operates without wear or maintenance.

Area of use

There are almost no restrictions to the device's areas of use as a limit switch in tanks, storage and intermediate containers, or to protect pumps from dry-running – thanks

Fault monitoring

The electronics module of LFV300 monitors continuously the following criteria:

- Strong corrosion or damage on the tuning fork
- Loss of vibration
- Line break to the piezo drive

Type overview

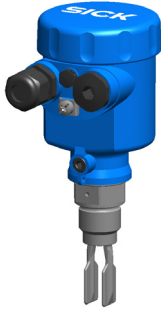
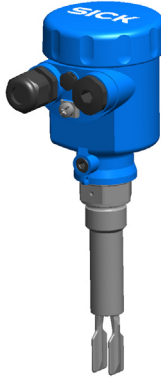
	LFV310	LFV330
		
Attributes		
Preferred application:	Liquids	Liquids
Length:	-	80... 6000 mm (3.15... 236.22 in) tube extension
Process connection:	Thread G $\frac{3}{4}$ A, G1 A, flanges, hygienic fittings	Thread G $\frac{3}{4}$ A, G1 A, flanges, hygienic fittings
Process temperature:	-50... +150 °C (-58... +302 °F) -50... +250 °C (-58... +482 °F) with temperature adapter	-50... +150 °C (-58... +302 °F) -50... +250 °C (-58... +482 °F) with temperature adapter
Process pressure:	-1 ... 64 bar (-14.5... 928 psi)	-1 ... 64 bar (-14.5... 928 psi)
Signal output:	Relay, transistor, NAMUR output, contactless electronic switch	Relay, transistor, NAMUR output, contactless electronic switch

Housing types



- 1 Plastic housing
- 2 Aluminium housing
- 3 Stainless steel

Dimensions

LFV310

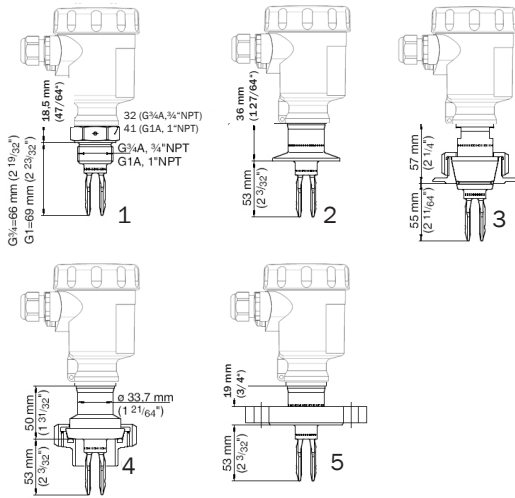

- 1 Thread
- 2 Tri-Clamp
- 3 Cone DN 25
- 4 Bolting DN 40
- 5 Flange

LFV330

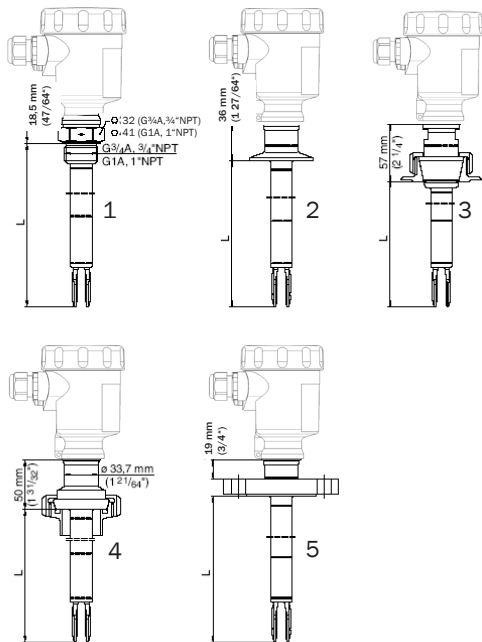

- 1 Thread
 - 2 Tri-Clamp
 - 3 Cone DN 25
 - 4 Bolting DN 40
 - 5 Flange
- L Sensor length, see chapter „Technical data“

Temperature adapter - LFV310/330

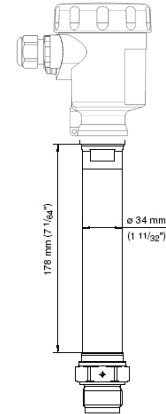

Electrical Connection

1. Preparing the connection

Note safety instructions

Always keep in mind the following safety instructions:
 ■ Connect only in the complete absence of line voltage
 Take note of safety instructions for Ex applications

Ex In hazardous areas you should take note of the appropriate regulations, conformity and type approval certificates of the sensors and power supply units.

Ex In hazardous areas, only use approved cable connections for LFV310/330.

Ex Select connection cable for Ex applications
 Take note of the corresponding installation regulations for Ex applications.

2. Wiring plan

Relay output

We recommend connecting LFV300 in such a way that the switching circuit is open when there is a level signal, line break or failure (safe condition).

The relays are always shown in non-operative condition.

LFV300 - oscillator with relay output

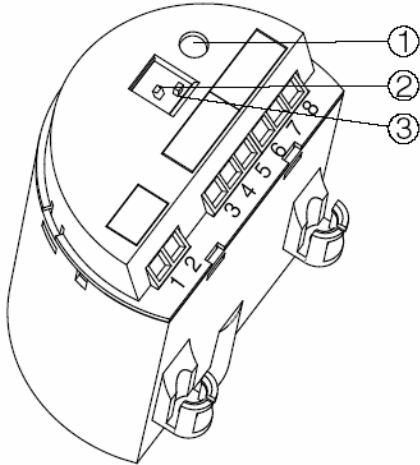

- 1 Control lamp
- 2 DIL switch for mode adjustment
- 3 DIL switch for sensitivity adjustment

LFV300 - wiring plan - relay output

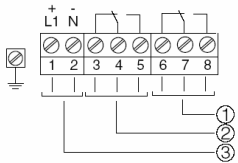

- 1 Relay output
- 2 Relay output
- 3 Voltage supply

Transistor output

We recommend connecting LFV300 in such a way that the switching circuit is open when there is a level signal, line break or failure (safe condition).

The instrument is used to control relays, contactors, magnet valves, warning lights, horns as well as PLC inputs.

LFV300 - oscillator with transistor output

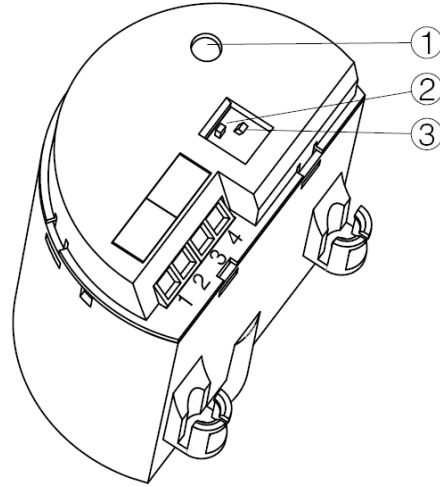

- 1 Control lamp
- 2 DIL switch for mode adjustment
- 3 DIL switch for sensitivity adjustment

LFV300 transistor output - NPN action

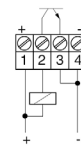

LFV300 transistor output - PNP action

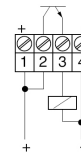

Contactless electronic switch

We recommend connecting LFV300 in such a way that the switching circuit is open when there is a level signal, line break or failure (safe condition).

The contactless electronic switch is always shown in non-operative condition.

The instrument is used for direct control of relays, contactors, magnet valves, warning lights, horns etc. It must not be operated without an intermediately connected load, because the electronics would be destroyed if connected directly to the mains. It is not suitable for connection to low voltage PLC inputs.

Domestic current is temporarily lowered below 1mA after switching off the load so that contactors, whose holding current is lower than the constant domestic current of the electronics, are reliably switched off.

When LFV300 is used as part of an overfill protection system according to WHG, also note the regulations of the general type approval.

LFV300 - oscillator with contactless electronic switch

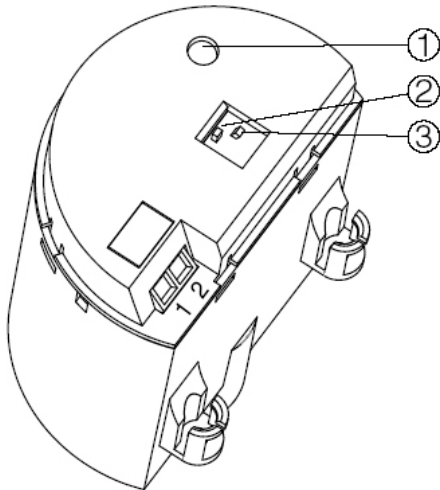

- 1 Control lamp
- 2 DIL switch for mode adjustment
- 3 DIL switch for sensitivity adjustment

LFV300 - wiring plan - output, contactless electronic switch

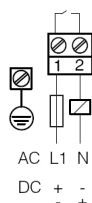

NAMUR output

LFV300 - oscillator with NAMUR electronics

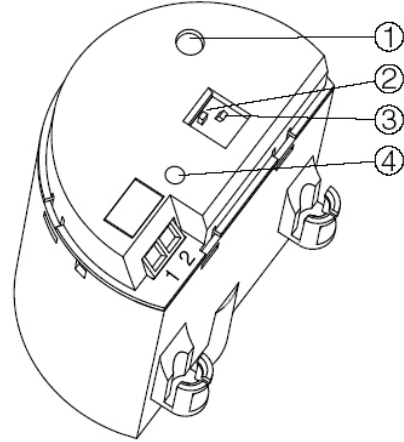

- 1 Control lamp
 - 2 DIL switch for characteristics reversal
 - 3 DIL switch for sensitivity adjustment
 - 4 Simulation key
- For connection of the amplifier according to NAMUR (IEC 60947-5-6, EN 50227).

LFV300 - Wiring plan - NAMUR output

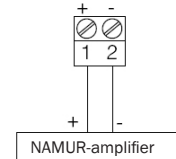

Simulation key

The simulation key is located in a recess on the upper side of the oscillator. Push the simulation key with a suitable object (screwdriver, pen, etc.).

When the key is pushed, a line break between sensor and processing unit is simulated. The signal lamp on the sensor extinguishes. The measuring system must signal a fault and take on a safe condition when the key is pushed.

Keep in mind that downstream connected instruments will be activated during operation. This allows you to check the correct function of the measuring system.

Characteristics reversal

The characteristics of the NAMUR electronics can be reversed with the DIL switch. You can choose between falling characteristic curve (switch position max.) and rising characteristic curve (switch position min.). You can thus have the desired current outputted.

Modes:

- min. - rising characteristic curve (High current when immersed)
- max. - falling characteristics (Low current when immersed)

The NAMUR-output can be switched to falling or rising characteristics.

For applications according to WHG, the DIL switch must be set to position max..

Technical data

Electric data

Process pressure	-1 ... 64 bar
Process temperature	-50 ... 150 °C (optional 250 °C)
Fill material density	> 0,5 ... 2.5g/cm ³
Viscosity	0.1 ... 10000 mPas
Materials, non-wetted parts	1.4404 (Optional Ra < 0,8 µm)
Material, housing	Aluminium, plastic, stainless steel
Response time	500 ms
Process connection	G ¾", G1", flange, triclamp, pipe connection DIN 11851 (further see type code)
Accuracy	± 2 mm
Reproducibility	± 1 mm
Hysteresis switching output	2 mm
Temperature drift	0,03 mm/K
Ambient temperature operation	-40 ... +70 °C
Ambient temperature storage	-40 ... +80 °C
Enclosure rating	IP66/67 or IP66/IP68 (0.2bar)
Length (only for LFV330)	80mm ... 6.000mm tube extension

	Electronic (Version T)	Electronic (Version C)
Switching output	Transistor output	Contactless electronic switch
Signal voltage HIGH	UV - 3 V	
Signal voltage LOW	< 1V	
Output current I _A	< 300 mA	< 400 mA
Output load		
Capacitive load	100 nF	100 nF
Inductive load	1 H	1 H
Supply voltage	10 ... 55 VDC	20 ... 253V AC/DC
Residual ripple	≤ 5 V _{pp}	
Current consumption	< 10 mA	< 4.2 mA
Initialization time	< 2 s	< 3 s
Protection class	<input type="checkbox"/>	<input checked="" type="checkbox"/>

	Electronic (Version R)	Electronic (Version N)
Switching output	Relay output	Namur output
Output current I _A	>10uA; <3A AC, 1A DC	1mA / 2,5mA
Output load		
Capacitive load	750VA 54W	
Inductive load	750VA 54W	
Supply voltage	20 ... 253VAC; 20 ... 72VDC	4,5 ... 12VDC
Current consumption	5 ... 30mA	1mA / 2,5mA
Initialization time	< 2 s	< 2 s
Protection class	<input checked="" type="checkbox"/>	<input type="checkbox"/>

Approvals

Overfill protection according to WHG	
ATEX	ATEX II 1G, 1/2G, 2G EEx ia IIC T6 ATEX II 1/2G, 2G EEx ia IIC T6
Marine certification	GL

Type code

LFV310									
Approval									
without approval	X	X							
Overfill protection acc. to WHG	X	A							
ATEX II 1G, 1/2G, 2G EEx ia IIC T6 + WHG	C	A							
ATEX II 1/2G, 2G EEx d IIC T6 + WHG	D	A							
ATEX II 1G, 1/2G,2G EEx ia IIC T6 + marine certification	C	M							
ATEX II 1/2G,2G EEx d IIC T6 + marine certification	D	M							
Marine certification	X	M							
Process fitting / Material									
Thread G ^{3/4} A PN64 / 316L			G	B	V				
Thread ^{3/4} NPT PN64 / 316L			N	B	V				
Thread G1 A PN64 / 316L			G	A	V				
Thread 1 NPT PN64 / 316L			N	A	V				
Tri-Clamp 1" PN16 / 316L Ra<0.3µm			C	C	N				
Tri-Clamp 1" PN16 / 316L Ra<0.8µm			C	C	P				
Tri-Clamp 2" PN16 / 316L Ra<0.3µm			C	A	N				
Tri-Clamp 2" PN16 / 316L Ra<0.8µm			C	A	P				
Bolting DN40 PN40 DIN11851 / 316L Ra<0,3µm			R	A	N				
Bolting DN40 PN40 DIN11851 / 316L Ra<0,8µm			R	A	P				
Varivent N50-40 / 316L Ra<0,8µm			T	A	P				
DRD-Flange PN40/316L ZB3007			D	A	V				
Flange DN25 PN40 Form C, DIN 2501 / 316L			F	P	V				
Flange DN50 PN40 Form C, DIN 2501 / 316L			F	E	V				
Flange DN40 PN40 Form C,DIN 2501/ 316L			F	C	V				
Flange DN80 PN40 Form C,DIN 2501/ 316L			F	I	V				
Flange 1" 150lb RF, ANSI B16.5 / 316L			A	P	V				
Flange 2" 150lb RF, ANSI B16.5 / 316L			A	C	V				
others on request									
Adapter / Process temperature									
without / -50...150°C								X	
with / -50...250°C								T	
Housing									
Plastic IP66/67 / M20x1.5									P
Plastic IP66/67 / ½NPT									N
Plastic IP66/67 / Plug M12x1 (4-pin)									T
Plastic IP66/67 / Plug M12x1 (5-pin)									W
Plastic IP66/67 / Plug M12x1(5-pin; EN50044)									Y
Plastic IP66/67 / Plug M12x1(4-pin; EN50044)									D
Aluminium IP66/IP67 / M20x1.5									M
Aluminium IP66/IP67 / ½NPT									U
Aluminium IP66/67 / Plug M12x1 (4-pin)									Z
StSt (electropolished) 316L / IP66/IP67 / M20x1.5									8
StSt (electropolished) 316L / IP66/IP67 / ½NPT									9
Electronics									
Contactless electronic switch 20...250VAC/DC									C
Double relay (DPDT) 20...72VDC/20...250VAC (3A)									R
Transistor (NPN/PNP) 10...55VDC									T
NAMUR signal									N
Switching point									
Standard									X
Switching point prolonged 118 mm									L

Type code

LFV330															
Approval															
without approval		X	X												
Overfill protection acc. to WHG		X	A												
ATEX II 1G, 1/2G, 2G EEx ia IIC T6 + WHG		C	A												
ATEX II 1/2G, 2G EEx d IIC T6 + WHG		D	A												
ATEX II 1G, 1/2G,2G EEx ia IIC T6 + marine certification		C	M												
ATEX II 1/2G,2G EEx d IIC T6 + marine certification		D	M												
Marine certification		X	M												
Process fitting / Material															
Thread G $\frac{3}{4}$ A PN64 / 316L				G	B	V									
Thread $\frac{3}{4}$ NPT PN64 / 316L				N	B	V									
Thread G1 A PN64 / 316L				G	A	V									
Thread 1 NPT PN64 / 316L				N	A	V									
Tri-Clamp 1" PN16 / 316L Ra<0.3µm				C	C	N									
Tri-Clamp 1" PN16 / 316L Ra<0.8µm				C	C	P									
Tri-Clamp 2" PN16 / 316L Ra<0.3µm				C	A	N									
Tri-Clamp 2" PN16 / 316L Ra<0.8µm				C	A	P									
Pipe connection DN40PN40 DIN11851 / 316L Ra<0,3µm				R	A	N									
Pipe connection DN40PN40 DIN11851 / 316L Ra<0,8µm				R	A	P									
Varivent N50-40 / 316L Ra<0,8µm				T	A	P									
DRD-Flange PN40/316L ZB3007				D	A	V									
Flange DN25PN40 Form C, DIN 2501 / 316L				F	P	V									
Flange DN50PN40 Form C, DIN 2501 / 316L				F	E	V									
Flange DN40PN40 Form C,DIN 2501/316L				F	C	V									
Flange DN80PN40 Form C,DIN 2501/316L				F	I	V									
Flange 1" 150lb RF, ANSI B16.5 / 316L				A	P	V									
Flange 2" 150lb RF, ANSI B16.5 / 316L				A	C	V									
others on request															
Adapter / Process temperature															
without / -50...150 °C										X					
with / -50...250 °C										T					
Housing															
Plastic IP66/67 / M20x1.5														P	
Plastic IP66/67 / $\frac{1}{2}$ NPT														N	
Plastic IP66/67 / Plug M12x1 (4-pin)														T	
Plastic IP66/67 / Plug M12x1 (5-pin)														W	
Plastic IP66/67 / Plug M12x1(5-pin; EN50044)														Y	
Plastic IP66/67 / Plug M12x1(4-pin; EN50044)														D	
Aluminium IP66/IP67 / M20x1.5														M	
Aluminium IP66/IP67 / $\frac{1}{2}$ NPT														U	
Aluminium IP66/67 / Plug M12x1 (4-pin)														Z	
StSt (electropolished) 316L / IP66/IP67 / M20x1.5														8	
StSt (electropolished) 316L / IP66/IP67 / $\frac{1}{2}$ NPT														9	
Electronics															
Contactless electronic switch 20...250VAC/DC														C	
Double relay (DPDT) 20...72VDC/20...250VAC (3A)														R	
Transistor (NPN/PNP) 10...55VDC														T	
NAMUR signal														N	
Length															
min. 80mm	max. 6000mm													0	0
														0	0

Mounting instructions

Switching point

In general, LFV300 can be installed in any position. The instrument simply has to be mounted in such a way that the vibrating element is at the height of the desired switching point.

The tuning fork has lateral markings (notches) marking the switching point with vertical installation. The switching point refers to the medium water with basic setting of the density switch $\geq 0.7 \text{ g/cm}^3$ (0.025 lbs/in^3).

Keep in mind that foams with a density $> 0.45 \text{ g/cm}^3$ (0.016 lbs/in^3) are detected by the sensor.

Socket

The vibrating element should protrude into the vessel to avoid build-up. For that reason, avoid using mounting bosses for flanges and screwed fittings. This applies particularly for horizontal installation and with adhesive products.

Agitators

Due to agitators, vibrations or similar, the level switch can be subjected to strong lateral forces. For this reason, do not use an overly long extension tube for LFV300, but check if you can mount a LFV200 or LFV310 level switch on the side of the vessel in horizontal position.

Extreme vibration caused by the process or the equipment, e.g. agitators or turbulence in the vessel, can cause the extension tube of LFV300 to vibrate in resonance. This leads to increased stress on the upper weld joint. Should a longer tube version be necessary, you can provide a suitable support or guy directly above the vibrating element to secure the extension tube.



This measure applies particularly to applications in Ex areas. Make sure that the tube is not subjected to bending forces through this measure.

Inflowing medium

If LFV300 is mounted in the filling stream, unwanted mismeasurements may result. Mount LFV300 at a location in the vessel where no disturbing influence from e.g. filling openings, agitators, etc. can occur.

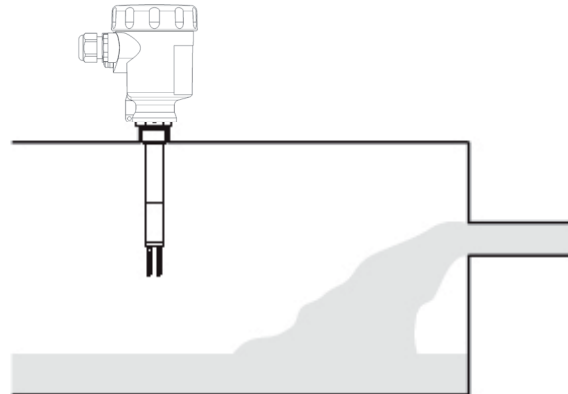

Flows

To minimise flow resistance caused by the tuning fork, LFV300 should be mounted in such a way that the surfaces of the blades are parallel to the product movement.

Measuring accuracy

Deviation ± 1 mm (0.04 in)

Influence of the process temperature on the switching point

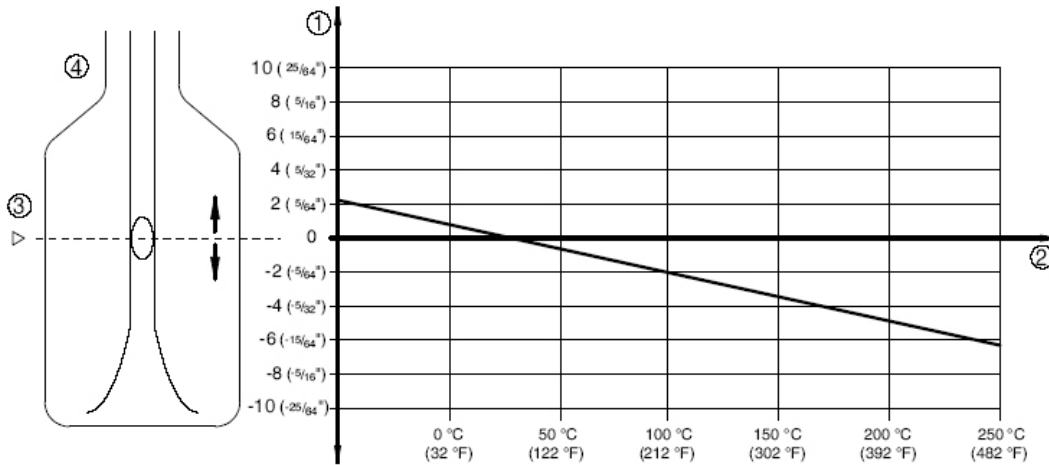

- 1 Shifting of the switching point in mm (in)
- 2 Process temperature in °C (°F)
- 3 Switching point at reference conditions (notch)
- 4 Tuning fork

Influence of the product density on the switching point

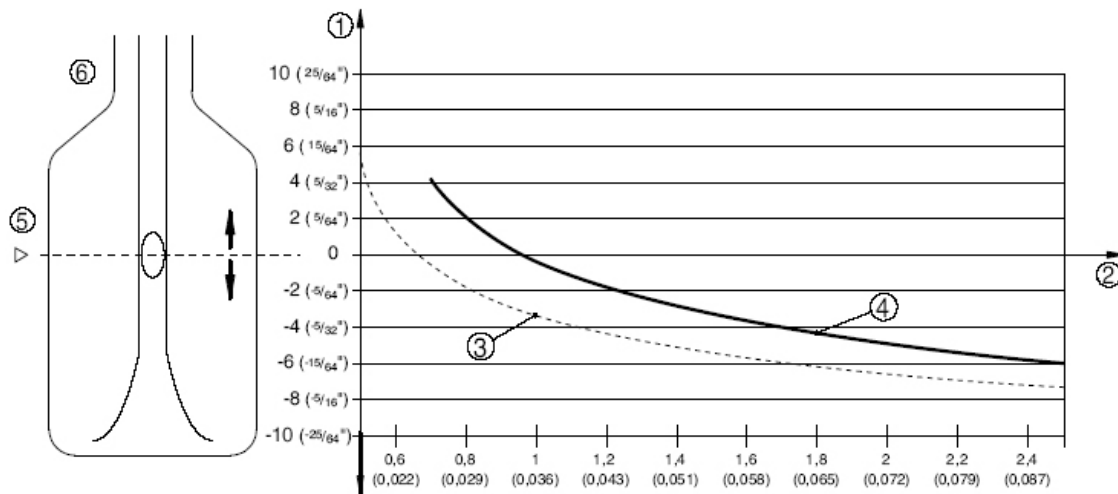

- 1 Shifting of the switching point in mm (in)
- 2 Product density in g/cm³ (lb/in³)
- 3 Switch position 0.5 g/cm³ (0.018 lb/in³)
- 4 Switch position 0.7 g/cm³ (0.025 lb/in³)
- 5 Switching point at reference conditions (notch)
- 6 Tuning fork

Influence of the process pressure to the switching point

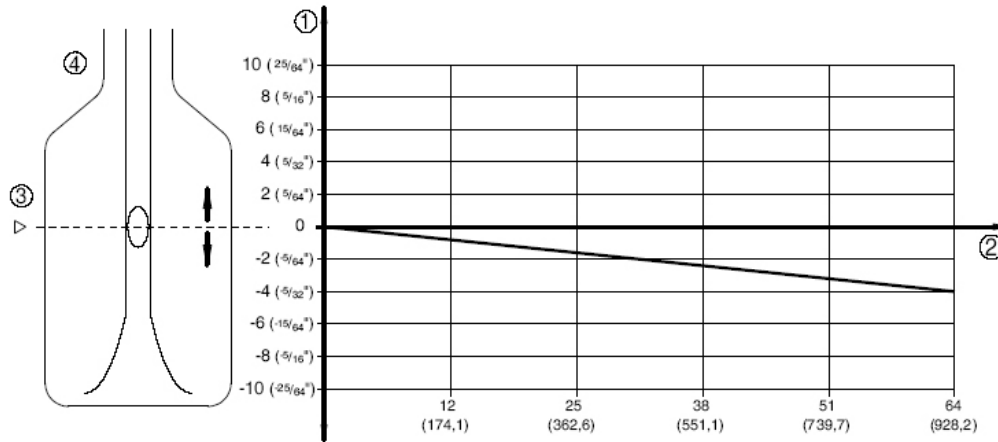

- 1 Shifting of the switching point in mm (in)
- 2 Process pressure in bar (psi)
- 3 Switching point at reference conditions (notch)
- 4 Tuning fork

Repeatability	0.1 mm (0.004 in)
Hysteresis	approx. 2 mm (0.08 in) with vertical installation
Switching delay	approx. 500 ms (on/off)
Frequency	approx. 1200 Hz

Ambient temperature - Product temperature

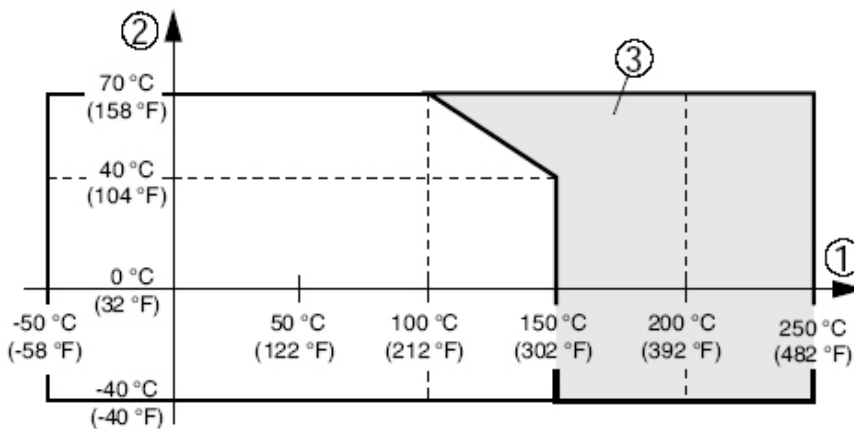

- 1 Product temperature
- 2 Ambient temperature
- 3 Temperature range with temperature adapter

Australia

Phone +61 3 9497 4100
1800 33 48 02 - tollfree
E-Mail sales@sick.com.au

Belgium/Luxembourg

Phone +32 (0)2 466 55 66
E-Mail info@sick.be

Brasil

Phone +55 11 3215-4900
E-Mail sac@sick.com.br

Ceská Republika

Phone +420 2 57 91 18 50
E-Mail sick@sick.cz

China

Phone +852-2763 6966
E-Mail ghk@sick.com.hk

Danmark

Phone +45 45 82 64 00
E-Mail sick@sick.dk

Deutschland

Phone +49 211 5301-250
E-Mail info@sick.de

España

Phone +34 93 480 31 00
E-Mail info@sick.es

France

Phone +33 1 64 62 35 00
E-Mail info@sick.fr

Great Britain

Phone +44 (0)1727 831121
E-Mail info@sick.co.uk

India

Phone +91-22-4033 8333
E-Mail info@sick-india.com

Israel

Phone +972-4-999-0590
E-Mail info@sick-sensors.com

Italia

Phone +39 02 27 43 41
E-Mail info@sick.it

Japan

Phone +81 (0)3 3358 1341
E-Mail support@sick.jp

Nederlands

Phone +31 (0)30 229 25 44
E-Mail info@sick.nl

Norge

Phone +47 67 81 50 00
E-Mail austefjord@sick.no

Österreich

Phone +43 (0)22 36 62 28 8-0
E-Mail office@sick.at

Polska

Phone +48 22 837 40 50
E-Mail info@sick.pl

Republic of Korea

Phone +82-2 786 6321/4
E-Mail kang@sickkorea.net

Republika Slovenija

Phone +386 (0)1-47 69 990
E-Mail office@sick.si

România

Phone +40 356 171 120
E-Mail office@sick.ro

Russia

Phone +7 495 775 05 34
E-Mail info@sick-automation.ru

Schweiz

Phone +41 41 619 29 39
E-Mail contact@sick.ch

Singapore

Phone +65 6744 3732
E-Mail admin@sicksgp.com.sg

Suomi

Phone +358-9-25 15 800
E-Mail sick@sick.fi

Sverige

Phone +46 10 110 10 00
E-Mail info@sick.se

Taiwan

Phone +886 2 2375-6288
E-Mail sickgrc@ms6.hinet.net

Türkiye

Phone +90 216 587 74 00
E-Mail info@sick.com.tr

USA/Canada/México

Phone +1(952) 941-6780
1 800-325-7425 - tollfree
E-Mail info@sickusa.com

More representatives and agencies
in all major industrial nations at
www.sick.com