

Features

- Device for hydrostatic pressure measurement in liquids or paste-like media
- Rod version
- Modular probe program to ensure optimum process adaptation
- Temperature range up to 85 °C (185 °F)
- Pressure range up to 10 bar (150 psi)
- Easy commissioning without the need for an operating tool
- Configurable by **PACTware**TM
- Up to SIL2 acc. to IEC 61508

Function

The device is used for level and pressure measurement in liquids or paste-like media.

The device has a hermetically sealed hydrostatic measuring cell.

Due to its weight, a liquid column creates hydrostatic pressure. This pressure is measured by the hydrostatic measuring cell. The hydrostatic measuring cell works on the principle of the gauge pressure sensor. Thanks to the hermetic sealing of the measuring element, the hydrostatic measuring cell is absolutely insensitive to condensate/condensation and aggressive gases. The pressure applied is transferred from the process isolating diaphragm to the measuring element by means of an oil without any loss in pressure.

The data is transmitted to the control via analog signal, HART protocol or PROFIBUS PA.

The device is easily configured by the use of keypad or with the PACTware configuration software.

The device is designed modular and offers a variety of process connections, a replaceable display and a universal electronics.

Assembly

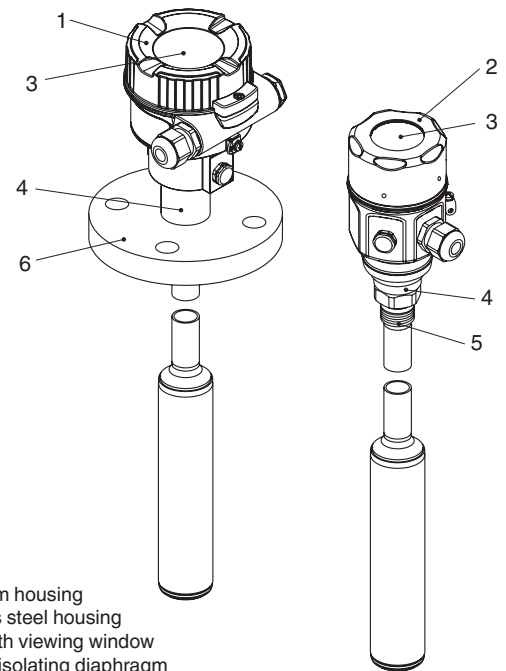

- 1 Aluminum housing
- 2 Stainless steel housing
- 3 Cover with viewing window
- 4 Process isolating diaphragm
- 5 Process connection (thread)
- 6 Process connection (flange)



SIL2

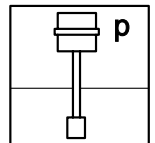

Connection

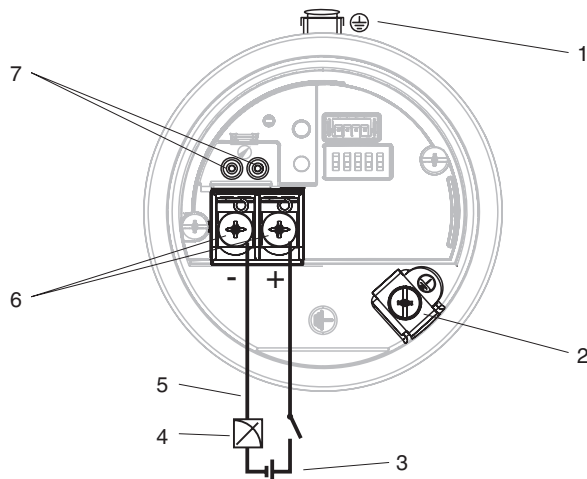

- 1 External grounding terminal
- 2 Internal grounding terminal
- 3 Supply voltage
- 4 4 mA to 20 mA for HART devices
- 5 For HART devices: With a handheld terminal, all the parameters can be configured anywhere along the bus line via menu operation.
- 6 Terminals
- 7 Test terminals for HART devices

Release date 2013-08-19 13:54 Date of issue 2013-08-19 t163862_eng.xml

Refer to "General Notes Relating to Pepperl+Fuchs Product Information".

General specifications	
Order code	see technical informations (TI)
Supply	
Rated voltage	versions for safe area: 11.5 ... 35 V DC, HART, 2-wire 9 ... 32 V DC, PROFIBUS PA version for hazardous area see safety information (SI)
Input	
Measured variable	hydrostatic pressure
Measurement range	0.1 ... 10 bar max. turn down: 20:1
Output	
Output signal	4 ... 20 mA with superimposed digital communication protocol HART 6.0, 2-wire digital communication signal PROFIBUS PA (Profile 3.02)
Communication	4 ... 20 mA HART (standard) PROFIBUS PA (option)
Conformity	
Protection degree	IEC 60529:2001
Measurement accuracy	
Accuracy	reference accuracy: 0.2 % (standard), 0.1 % (platinum) The reference accuracy comprises the non-linearity according to limit point setting, hysteresis and non-reproducibility acc. to IEC 60770. The data refer to the calibrated span.
Long-term drift	up to 0.05 % of upper range limit (URL)/year up to 0.125 % of upper range limit (URL)/5 years
Operating conditions	
Process conditions	
Medium temperature	-40 ... 85 °C (-40 ... 185 °F)
Ambient conditions	
Ambient temperature	-40 ... 85 °C (-40 ... 185 °F) with display : -20 ... 70 °C (-4 ... 158 °F)
Storage temperature	-40 ... 90 °C (-40 ... 194 °F)
Mechanical specifications	
Protection degree	IP66, NEMA 4X IP68, NEMA 6P (24 hours in water 1.83 m (6 ft) deep) IP69K (with separate housing and FEP cable)
Connection	gland M20 thread M20, G1/2, NPT1/2 device plug M12 HAN7D Harting connector, angled valve connector acc. ISO 4400, cable 5 m
Material	process connections: AISI 316L (1.4435 or 1.4404), Alloy C276 (2.4819) housing: - die-cast aluminum with protective powder-coating on polyester base, housing F31 - stainless steel AISI 316L (1.4404), housing F15 rod: AISI 316L (1.4404) or Alloy C276 (2.4819) process isolating diaphragm: Alloy C276 (2.4819), Rhodium Gold Alloy C276, Platinum Gold Alloy C276 sealing measuring cell: welded measuring cell or FKM Viton, EPDM, Kalrez
Process connection	threads ISO 228: G1/2, threads ANSI: NPT1/2 flanges EN 1092-1: DN 40 ... DN 100, flanges ANSI 16.5: 2 ... 4 in, flanges JIS B2220
Data for application in connection with Ex-areas	
EC-Type Examination Certificate	see safety information (SI)
International approvals	
FM approval	see safety information (SI)
CSA approval	see safety information (SI)
IECEx approval	see safety information (SI)
Certificates and approvals	
Drinking water approval	NSF61 approval
Overspill protection	see approvals (ZE)
Marine approval	German Lloyd (GL)
General information	
Supplementary documentation	technical informations (TI) operating instructions (BA, KA) safety information (SI) control drawings (ZD) approvals (ZE)
Supplementary information	EC-Type Examination Certificate, Statement of Conformity, Declaration of Conformity, Attestation of Conformity and instructions have to be observed where applicable. For information see www.pepperl-fuchs.com .
Accessories	

Release date 2013-08-19 13:54 Date of issue 2013-08-19 t163862_eng.xml

Refer to "General Notes Relating to Pepperl+Fuchs Product Information".

Pepperl+Fuchs Group
www.pepperl-fuchs.com

USA: +1 330 486 0002
pa-info@us.pepperl-fuchs.com

Germany: +49 621 776 2222
pa-info@de.pepperl-fuchs.com

Singapore: +65 6779 9091
pa-info@sg.pepperl-fuchs.com

Designation	see technical informations (TI)
-------------	---------------------------------

Release date 2013-08-19 13:54 Date of issue 2013-08-19 t163862_eng.xml

Refer to "General Notes Relating to Pepperl+Fuchs Product Information".

Pepperl+Fuchs Group
www.pepperl-fuchs.com

USA: +1 330 486 0002
pa-info@us.pepperl-fuchs.com

Germany: +49 621 776 2222
pa-info@de.pepperl-fuchs.com

Singapore: +65 6779 9091
pa-info@sg.pepperl-fuchs.com

Dimensions (excerpt)

Housing F31, aluminum (versions I, J)

Dimensions in mm (in)

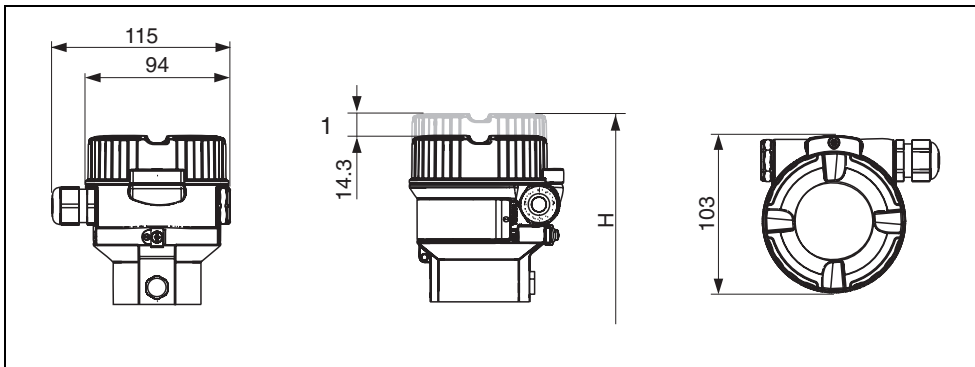

1 The cover with viewing window is 15 mm (0.59 in) higher than the cover without viewing window.

Housing F15, stainless steel (versions Q, R, S, hygienic)

Dimensions in mm (in)

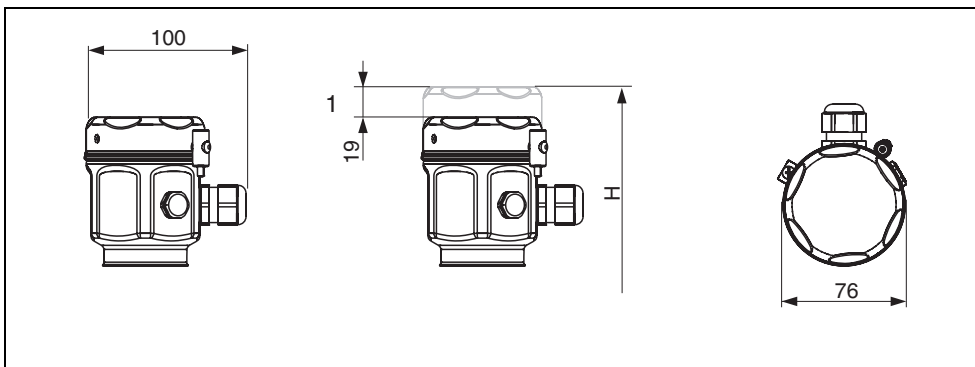

1 The cover with viewing window is 19 mm (0.75 in) higher than the cover without viewing window.

Dimensions (excerpt)

Process connections with thread

Dimensions in mm (in)

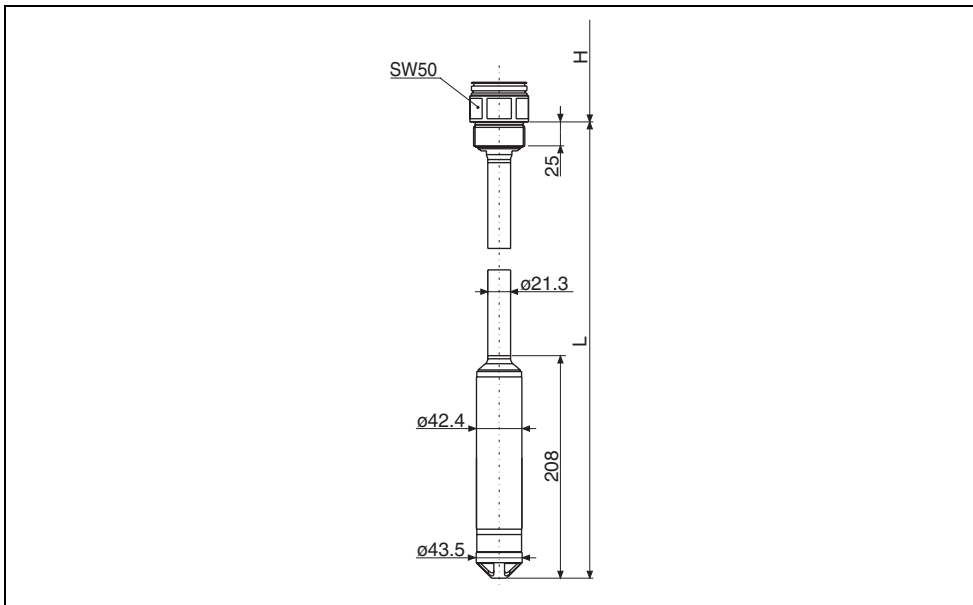

Rod version with thread G1-1/2 or 1-1/2 NPT

L Probe length L = 0.4 m to 4 m (1.3 ft to 13 ft)

	F31 housing (I, J)	F15 housing (Q, R, S)
Height H	156 mm (6.14 in)	148 mm (5.83 in)

Process connections with EN/DIN and ANSI flanges

Dimensions in mm (in)

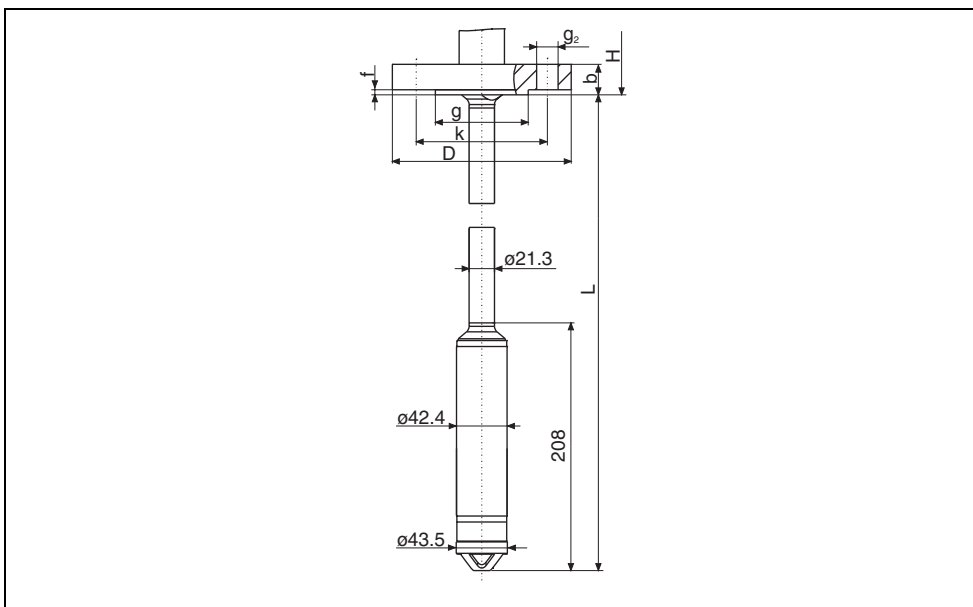

Rod version with flange

L Probe length L = 0.4 m to 4 m (1.3 ft to 13 ft)

Description	F31 housing (I, J)	F15 housing (Q, R, S)
Height H	165 mm (6.5 in)	157 mm (5.18 in)



For further information see technical information.

Release date 2013-08-19 13:54 Date of issue 2013-08-19 1163862_eng.xml